

REV.	DESCRIPTION	DATE	DWG	CH'D	CH'D	APP'D
△	First Issued	'18.06.01	J.Y.CHO	CH.R.KIM	-	C.G.LEE

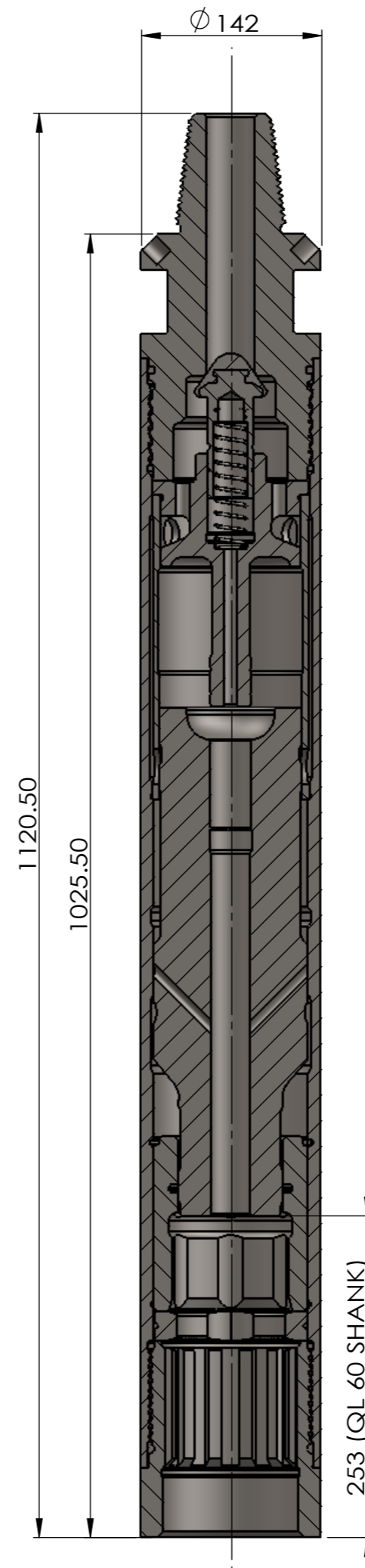

품번	품명	수량
1	Wearsleeve QL	1
2	BACKHEAD & O-RING	1
3	CHECK VALVE & SPRING	1
4	AIR DISTRIBUTER	1
5	CYLINDER	1
6	PISTON	1
7	PISTON STOP RING	1
8	Piston Bush QL	1
9	Bit ring QL	1
10	Chuck QL	1

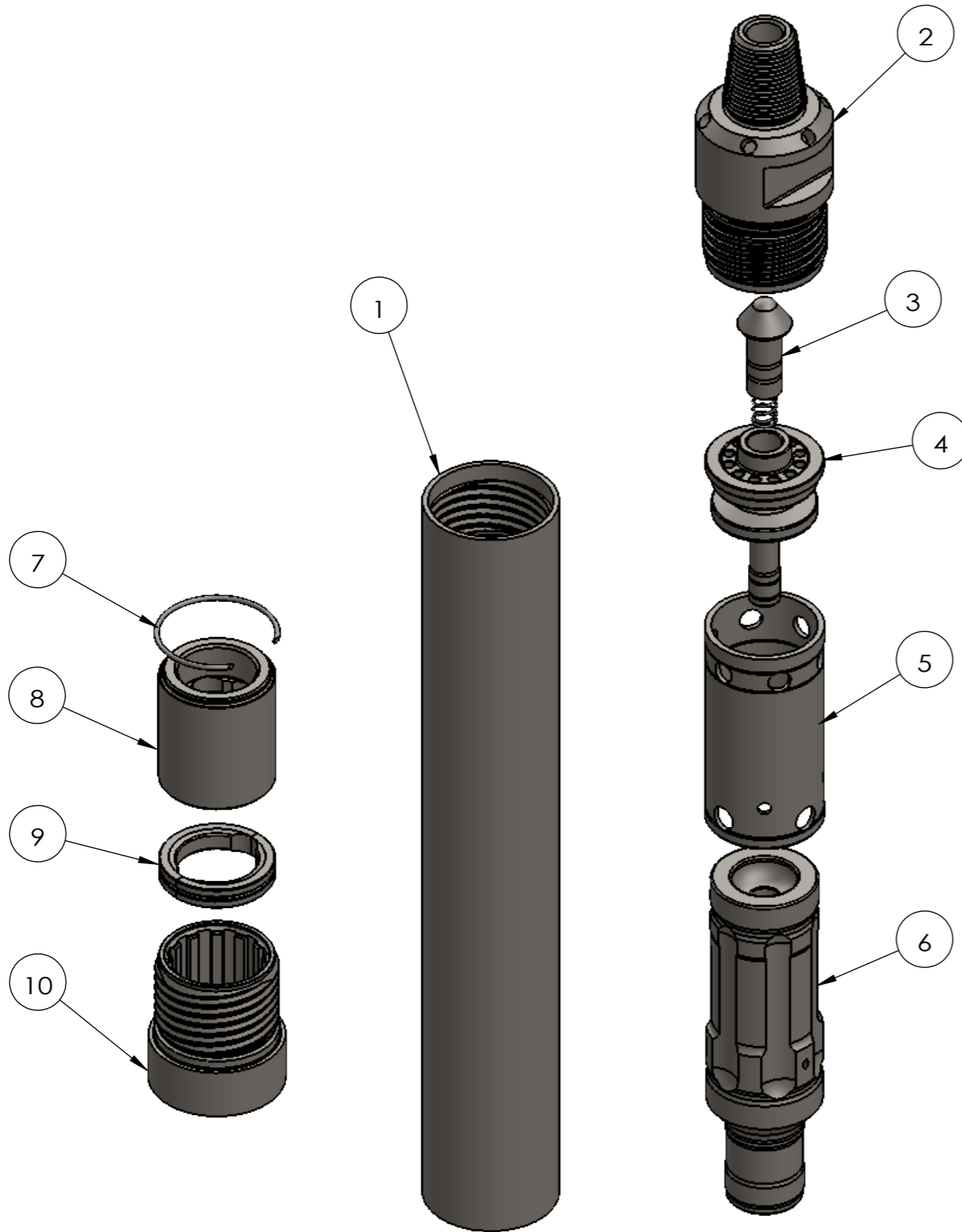

CHANG-SHIN INT'L CO.,LTD
ULSAN KOREA

APP'D		TITLE	NMG_6인치 QL Hammer Assy	
CH'D		MATERIAL	Model	
CH'D		Standard	NMG_6" Hammer	
DRAW		Proj	3각법	DWG NO.
DATE	SIGN.	Weight	90 kg	CS-NMG-60-QL-00