

REV.	DESCRIPTION	DATE	DWG	CH'D	CH'D	APP'D
△	First Issued	'19.02.08	CH.R.KIM	-	-	C.G.LEE

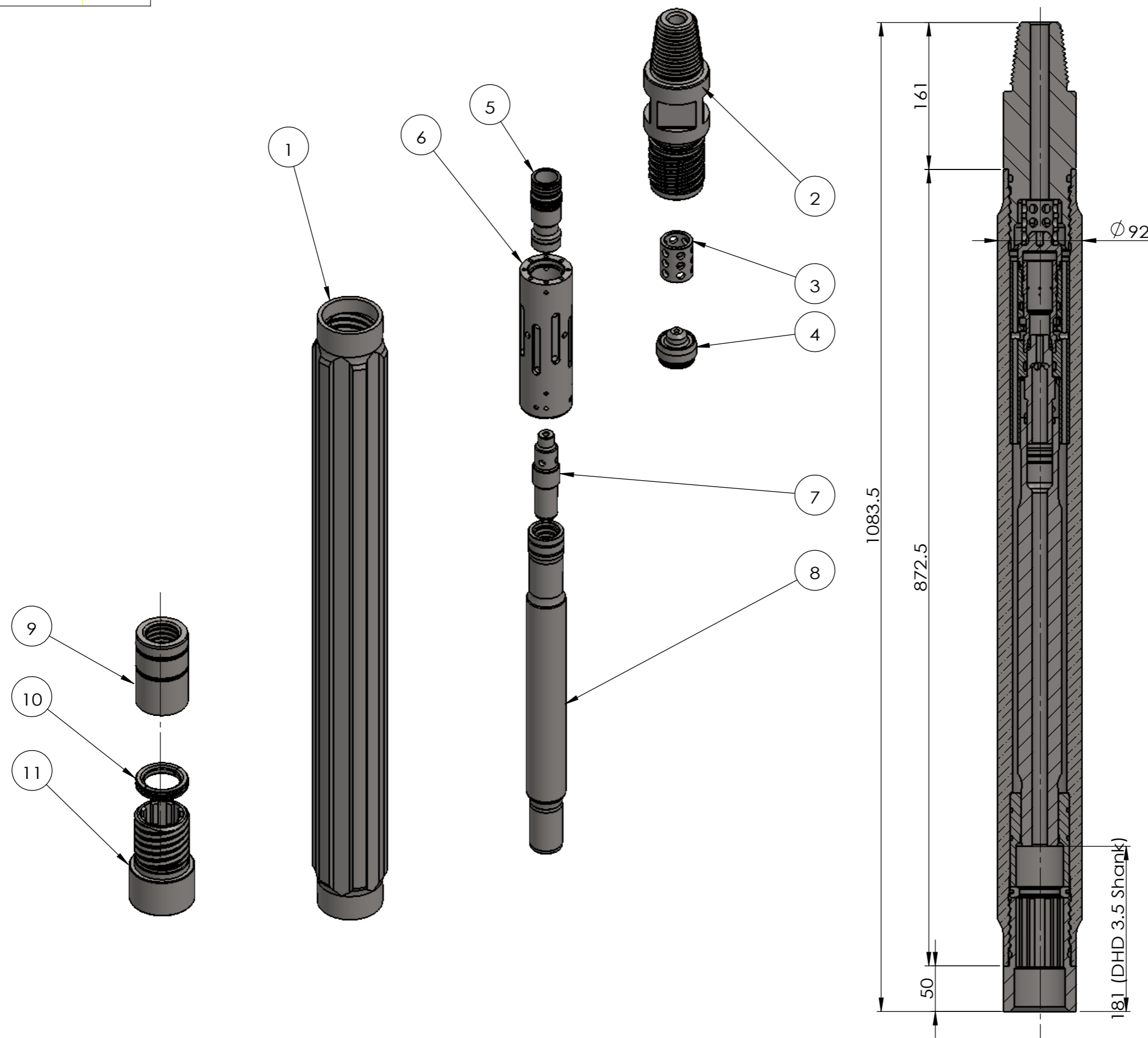

품번	품명	수량
1	WEAR SLEEVE_W30_V4.0	1
2	BACKHEAD_W30_V4.0	1
3	Filter Ring_W30_V4.0	1
4	Valve Cover_W30_V4.0	1
5	Valve_W30_V4.0	1
6	Valve Housing_W30_V4.0	1
7	Sliding Tube_W30_V4.0	1
8	Piston_W30_V4.0	1
9	PISTON BUSH_W30_V3.0	1
10	BIT RING_W30_V3.0	1
11	CHUCK_W30_V3.0	1

CS CHANG-SHIN INT'L CO.,LTD
ULSAN KOREA

APP'D		TITLE	Water Powered DTH Hammer
CH'D		MATERIAL	STD
CH'D		MODEL	W30_V4.0
DRAW		Proj	3각법
DATE	SIGN.	Weight	34 kg
		DWG NO.	CS-W30-H