

REV.	DESCRIPTION	DATE	DWG	CH'D	CH'D	APP'D
△	도면정리를 위한 신규 등록	'11.08.31	J.M.SEO	CR.R.KIM	T.Y.JANG	C.K.LEE
△	B/H 와 W/S 조립용새 2.5 → 2 CHUCK 과 W/S 조립용새 0 → 0.4	'15.07.15	J.M.SEO	CR.R.KIM	S.I.SONG	C.K.LEE

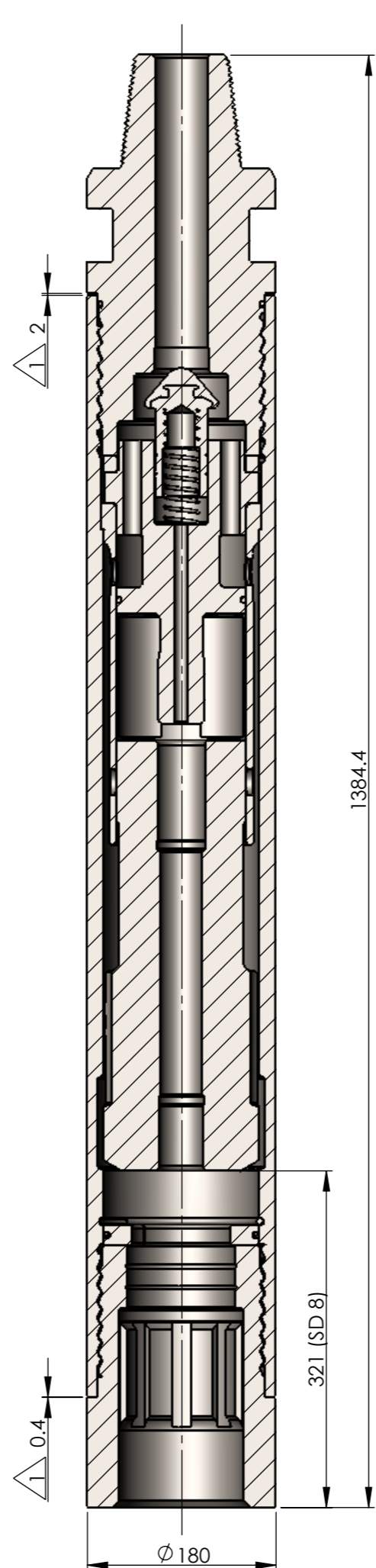
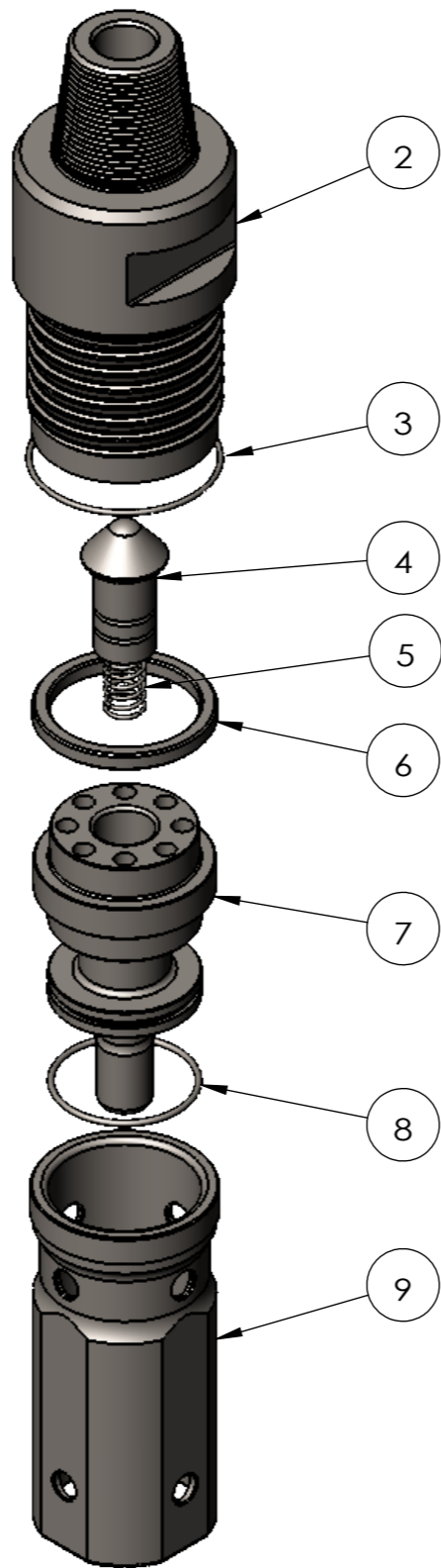
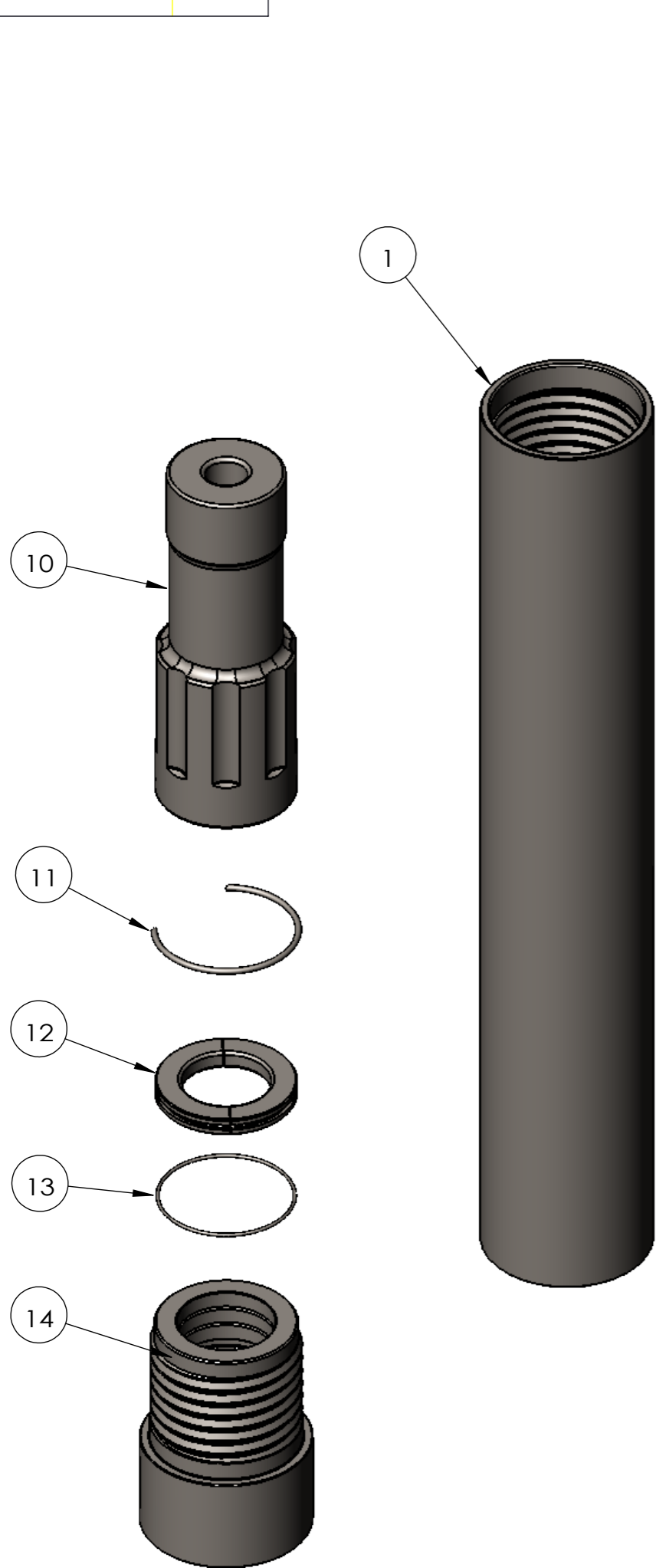

품번	품명
1	WEAR SLEEVE
2	BACKHEAD
3	BACKHEAD O-RING
4	CHECK VALVE
5	CHECK VALVE SPRING
6	BUFFER RING
7	AIR DISTRIBUTOR
8	AIR DISTRIBUTOR O-RING (U-346)
9	CYLINDER
10	PISTON
11	PISTON STOP RING
12	BIT RETAINING RING
13	BIT RETAINING RING O-RING (P-110)
14	CHUCK

CS CHANG-SHIN INT'L CO.,LTD
ULSAN KOREA

APP'D	'11.08.31	TITLE	CS-80MS Hammer Assy	
CH'D	-	MATERIAL	MODEL	
CH'D	'11.08.31	STANDARD	CS-80MS	
DRAW	'11.08.31	Proj	3각법	DWG NO.
DATE	SIGN.	Weight	189kg	CS-80-MS-00