

REV.	DESCRIPTION	DATE	DWG	CH'D	CH'D	APP'D
△	도면정리를 위한 신규 등록	'11.07.27	J.M.SEO	CR.R.KIM	T.Y.JANG	C.K.LEE
△	B/H 와 W/S 조립公差 2mm → 1.5mm CHUCK 과 W/S 조립公差 0 → 0.4mm	'15.07.15	J.M.SEO	CR.R.KIM	S.I.SONG	C.K.LEE

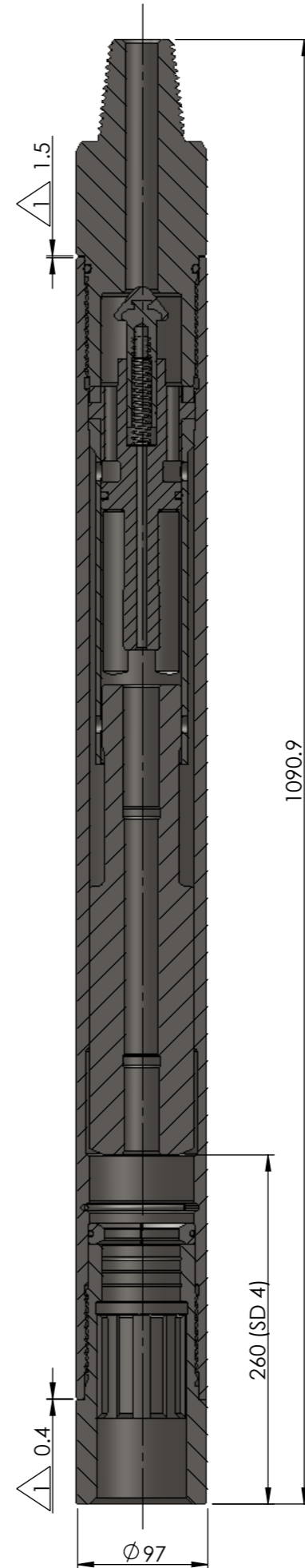
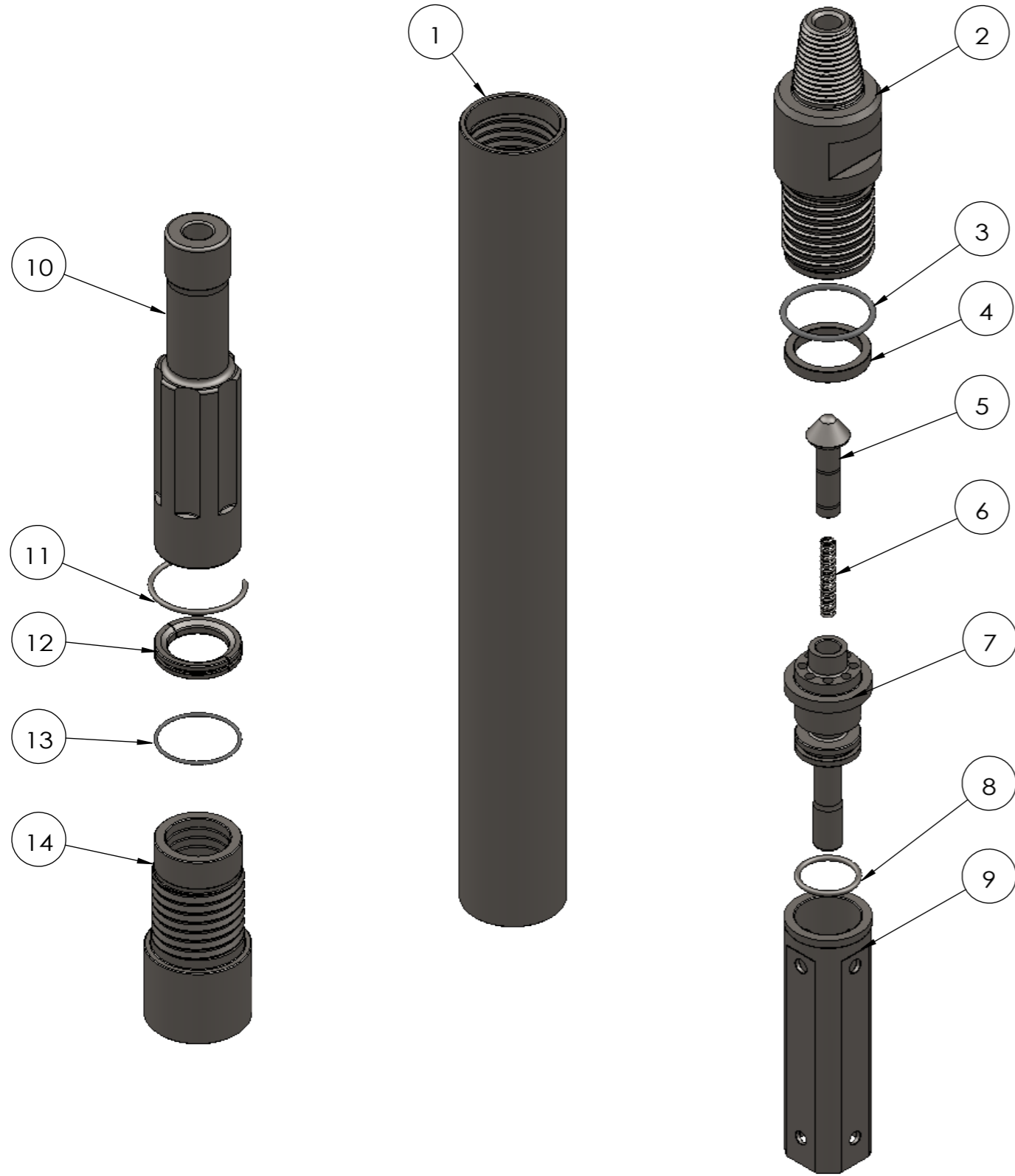

품번	품명
1	WEAR SLEEVE
2	BACKHEAD
3	BACKHEAD O-RING(U-336)
4	BUFFER RING
5	CHECK VAVLE
6	CHECK VAVLE SPRING
7	AIR DISTRIBUTOR
8	AIR DISTRIBUTOR O-RING (U-329)
9	CYLINDER
10	PISTON
11	PISTON STOP RING
12	BIT RETAINING RING
13	BIT RETAINING RING O-RING (G-70)
14	CKUCK

CS CHANG-SHIN INT'L CO.,LTD
ULSAN KOREA

APP'D	DATE	TITLE		
	'11.07.27	CS-40MS Hammer Assy		
CH'D	DATE	MATERIAL	MODEL	
	-		CS-40 MS	
CH'D	DATE	STANDARD	MODEL	
	'11.07.27		CS-40 MS	
DRAW	DATE	Proj	3각법	DWG NO.
	'11.07.27		☑	CS-40-MS-00
DATE	SIGN.	Weight	DWG NO.	
		41.5 KG		