

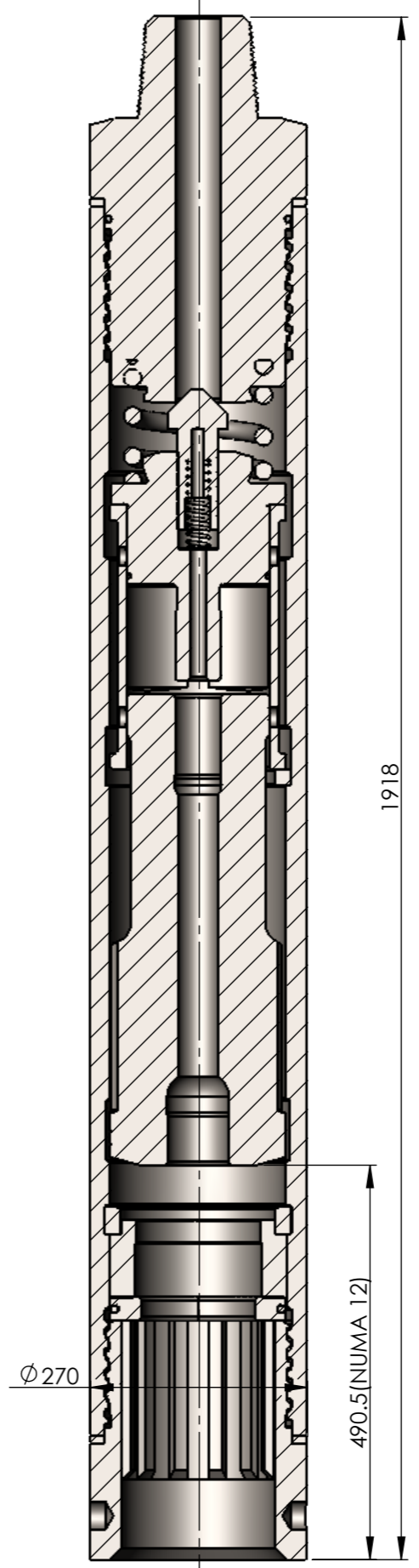

REV.	DESCRIPTION	DATE	DWG	CH'D	CH'D	APP'D
△	도면정리 최초 등록.	'17.05.09	CH.R.KIM	-	-	C.G.LEE
△	Guide Bush 수정.	'17.05.18	CH.R.KIM	-	-	C.G.LEE

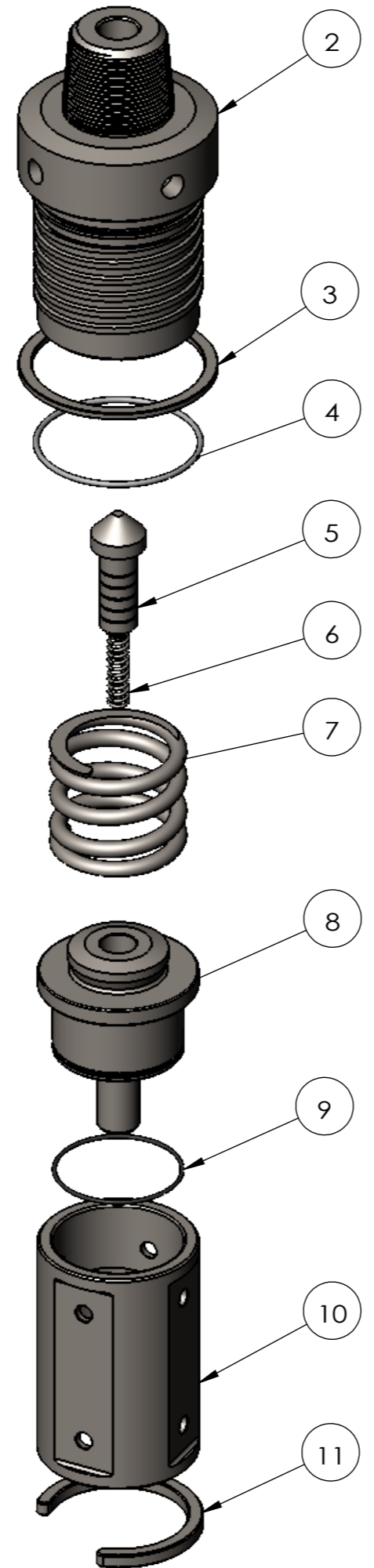

품번	품명
1	WEAR SLEEVE
2	BACKHEAD
3	BACKHEAD WASHER
4	BACKHEAD O-RING
5	CHECK VALVE
6	CHECK VALVE SPRING
7	BUFFER SPRING
8	AIR DISTRIBUTOR
9	AIR DISTRIBUTOR O-RING
10	CYLINDER
11	CYLINDER STOP RING
12	PISTON
13	PISTON STOP RING
14	GUIDE BUSH_rev.1
15	BIT RETAINING RING(IR 공통사용)
16	BIT RETAINING RING O-RING
17	CHUCK WASHER
18	CHUCK

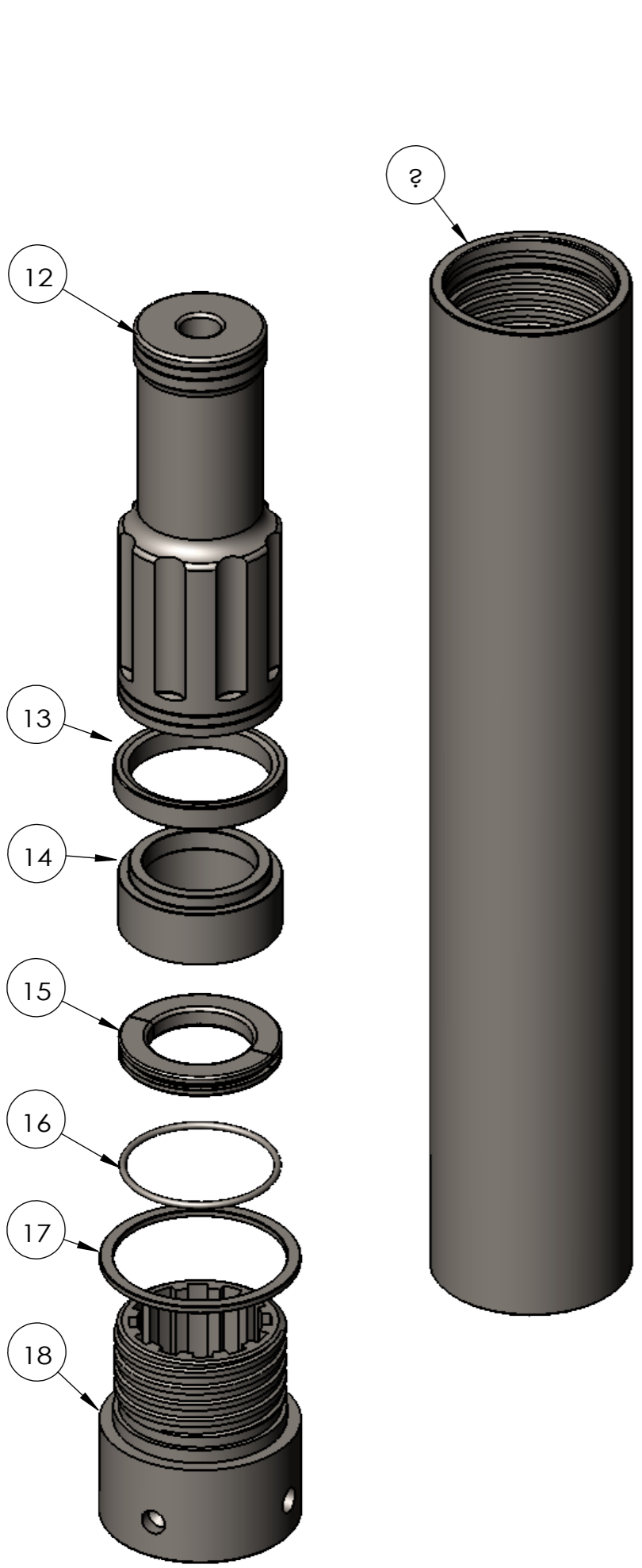

CHANG-SHIN INT'L CO.,LTD
ULSAN KOREA

APP'D	-	TITLE	CS-112NUMA Hammer Assy	
CH'D	-	MATERIAL		MODEL
CH'D	-	STANDARD	CS-112NUMA	
DRAW	-	Proj	3각법	DWG NO.
DATE	SIGN.	Weight	595 kg	CS-112NUMA-00